

# REC duo 100

Decentralized Heat Recovery Unit

**Coupled installation in a single room or 2 separate rooms**



**Comply with ErP Directive 2009/125/CE and EU Regulation 1253/2014.**  
Residential Ventilation Unit.

**Energy class A+**  
(with humidity control)

- **Thermal efficiency up to 90%**
- Ø100
- **Easy Installation and maintenance:**
  - Magnetic coupling/uncoupling of the unit.
  - External grille with net installable from the inside.
  - Telescopic duct.
- **Wireless communication (Rec Duo 100 Plus RC)**

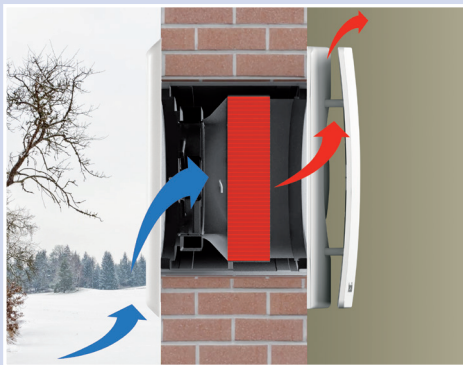

REC Duo 100 is a "push-pull" HRU with reverse flow. It is provided with a ceramic heat exchanger that accumulates the heat from the extracted air during the "pull" cycle and releases it to the new fresh air during the "push" cycle.

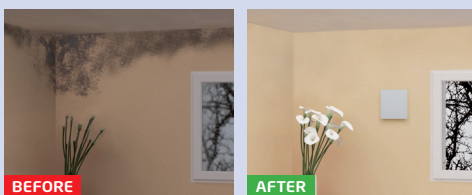
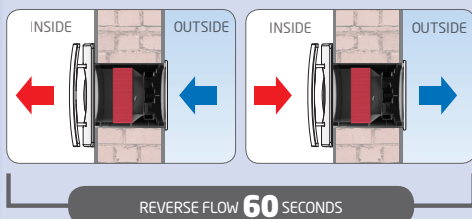

The system effectively helps to prevent the formation of mold on the walls when caused by insufficient natural ventilation.

## FEATURES

- Very high efficiency decentralized HRU with heat recovery up to 90%.
- Ideal for residential applications and in any ambient where it is necessary to ensure a constant thermal comfort both in the summer and in the winter.
- Suitable for any kind of rooms.
- A coupled installation is recommended to optimize the system efficiency, in a single room or separate rooms.
- Direct exhaust through walls with thickness from 300 to 500 mm (adaptable to other wall thickness from 220 to 1000 mm: see section Dimensions).
- Suitable for conveying air to a max. temperature of 50°C.
- Stylish and ultra-slim front cover. Very compact dimensions.
- Provided with filters G3 class both in intake and in extract, easily removable and washable.
- Free-cooling function.
- EC brushless motor
- Comply with EN 60335-2-80, LVD 2014/35/UE, EMC 2014/30/UE.
- IPX4
- **CE**marked

## EXAMPLES OF INSTALLATION

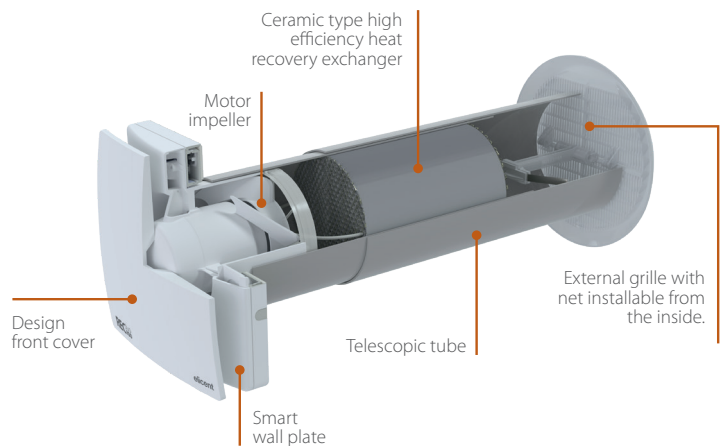
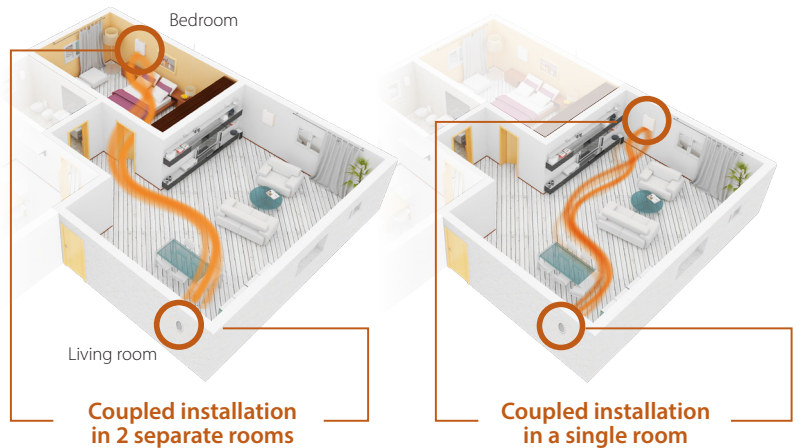

**MAGNETIC COUPLING UNCOUPLING OF THE UNIT TO THE CONNECTION PLATE**



# MODELS & OPERATION



## REC DUO 100

24 hours running in push-pull modality at low speed (selectable between 2 at installation).

The unit switches to the extraction operation modality when speed boost is activated through remote control switch or RLS controller (available as accessory). The maximum speed is provided with a timer (adjustable from 0 to 30 minutes). Once concluded the overrun via timer, the fan automatically switches back to the push-pull operation modality at low speed.



## REC DUO 100 MHY

24 hours running in push-pull modality at low speed (selectable between 2 at installation). The unit switches to the extraction operation modality when speed boost is activated, manually or automatically:

**Manually** via control switch or RLS controller (available as accessory). The maximum speed is provided with a timer (adjustable from 0 to 30 minutes). Once concluded the overrun via timer, the fan automatically switches back to the push-pull operation modality at low speed.

**Automatically** via humidistat (adjustable from 45 to 85% of R.H). The fan speed increases/decreases according to the humidity level detected above the pre-selected threshold. It then switches back to the push-pull operation modality at low speed when the humidity level goes beneath the pre-selected threshold.

## RLS

Available as accessory for REC DUO 100 and REC DUO 100 MHY



- On-Off  
- Boost Selection (extraction mode)



## REC DUO 100 PLUS RC

24 hours running in push-pull modality at low speed (adjustable by the end-user).

Boost speed is available in push-pull modality and turns on automatically via humidistat (adjustable from 45 to 85% of R.H) and increases/decreases progressively according to the detected humidity level.

In case of a persistent and high concentration of humidity, the unit automatically switches to the extraction operation modality. It then switches back to the push-pull operation modality at low speed when the humidity level goes beneath the pre-selected threshold. The unit is supplied with a remote controller for the selection and activation of advanced comfort ventilation functions.

REC DUO 100 PLUS RC is supplied with a remote controller through which selecting the speed and managing the following operation modalities:

### 0 - On/Off

**1 - Push-pull operation modality**  
24 hours reverse flow running at the selected speed

### 2 - Speed 1

### 3 - Speed 2

### 4 - Boost speed with timer (extraction mode only)

### 5 - Sleep mode

the operation at low speed is frozen for 8 hours to ensure high acoustic comfort during the night. The function can be unblocked at any time by pressing any button (except button 0).

### 6 - Flow control

operation in intake or extract mode only.  
Press once: extraction mode  
Press twice: intake mode

### 7 - Free-cooling mode: air exchange without heat recovery



**Led signal:** any time a button is pressed, a led switches on the remote controller to indicate that the signal has been received.

# PERFORMANCE

MODEL	DUCT	WALL THICKNESS	AIRFLOW min / max / only exhaust	V at 50 Hz	W min / max / only exhaust	dB(A)*
	Ø (mm)	min max (mm)	m³/h			Lp
REC Duo 100 / 100 MHY / 100 PLUS RC	107	300 - 500	12 / 30 / 40	230	1 / 2,8 / 3,5	15 / 29

\* measured at 3 m in open field

# DIMENSIONS (mm)

External grille installable from the inside

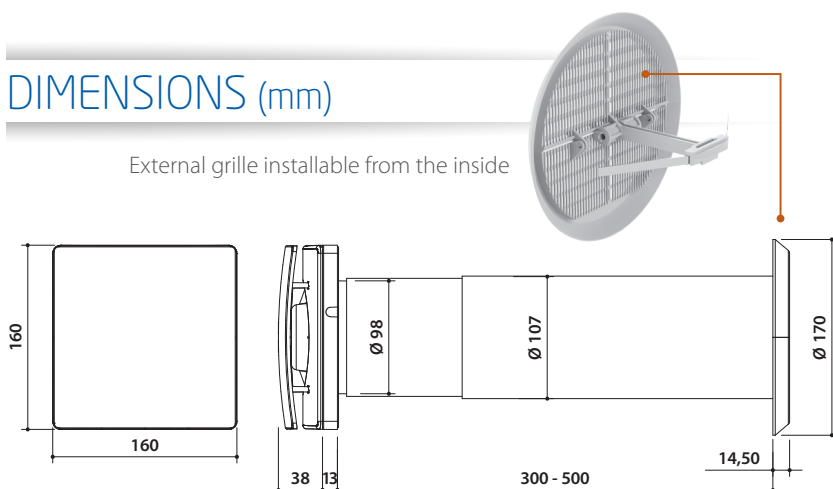

### For walls with thickness > 500 mm:

It is necessary to use the telescopic duct available as accessory

**Cod. 2KT0014**

### For wall thickness between 220 and 300 mm:

it is necessary to cut the duct and to use the external grille MFE, available as accessory,

**Cod. 2GE2002**

