

	TRIFASE		MONOFASE	
	SCHEMA N°	Pagina	SCHEMA N°	Pagina
CC-JC HT	SE04	3		
CC-JD HT	SE04	3		
CC-JD LP HT	SE04	3		
CC-S HT	SE06	5		
CMP	SE06	5	SE11	11
CMZ	SE05T	4	SE05M	4
ELIBOX	SE02T	1	SE02M	1
FC HT	SE06	5		
HT	SE06	5		
IC	SE06	5	SE11	10
IC ATEX	SE06	5	SE12	11
ICA	SE06	5	SE11	10
ICA ATEX	SE06	5		
ICS	SE06	5		
ICS ATEX	SE06	5		
IEL	SE10T	9	SE10M	9
IEM	SE06	5	SE11	10
IES			SE09	8
MBX	SE03	2		
PF	SE06	5		
PMP	SE05T	4	SE05M	4
TAC-N	SE06	5	SE11	10
TC HT	SE06	5		
TCF	SE06	5	SE11	10
TCF 2V	SE04	3		
TCF AT	SE06	5		
TCF AT 2V	SE04	3		
TCF ATEX	SE06	5	SE12	11
TCF-V ATEX	SE06	5	SE12	11
TCR	SE08T	7	SE08M	7
TCV	SE06	5	SE11	10
TCV 2V	SE04	3		
ZOO	SE06	5		

SE02

SE02 M

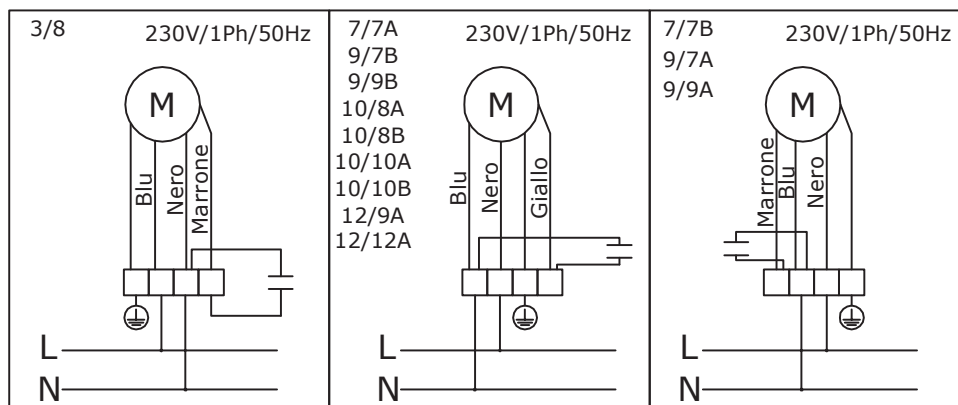

SE02 T

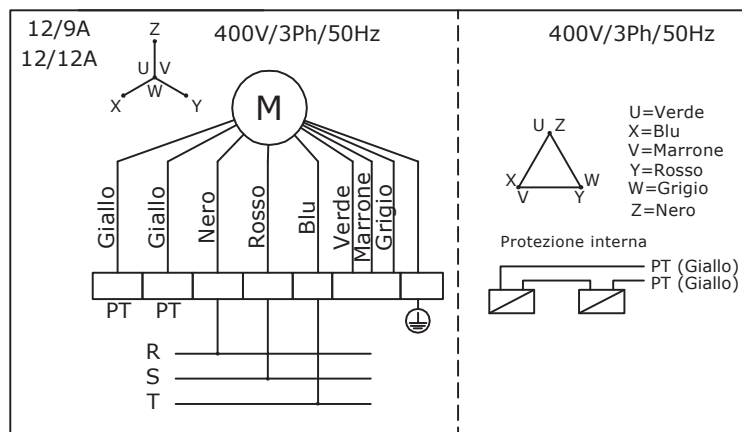

## SE03

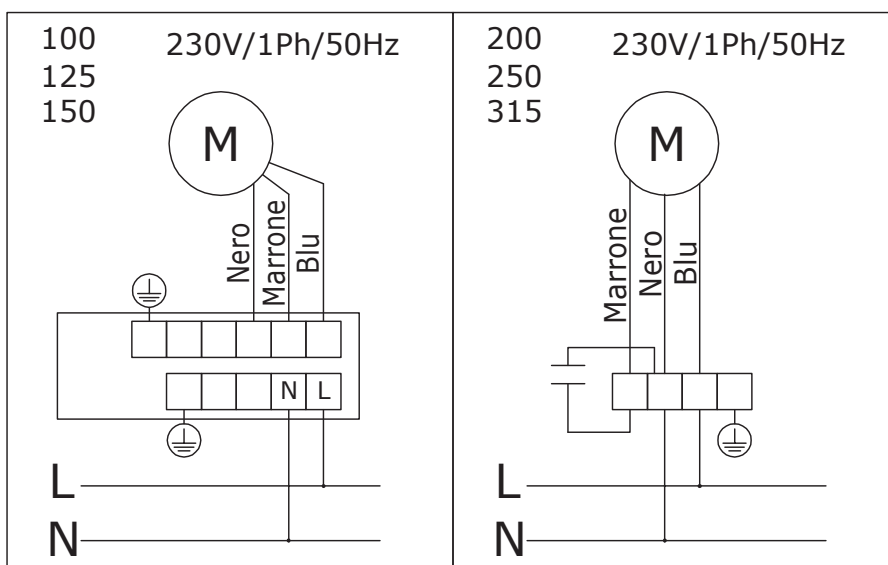

SE04

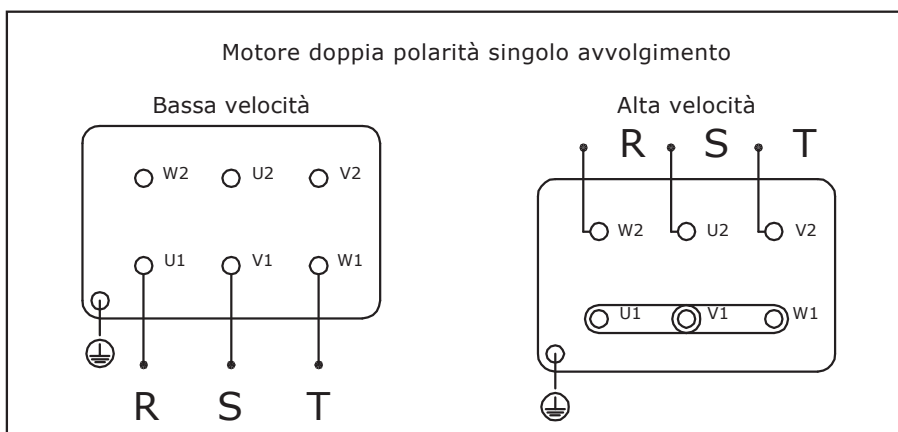
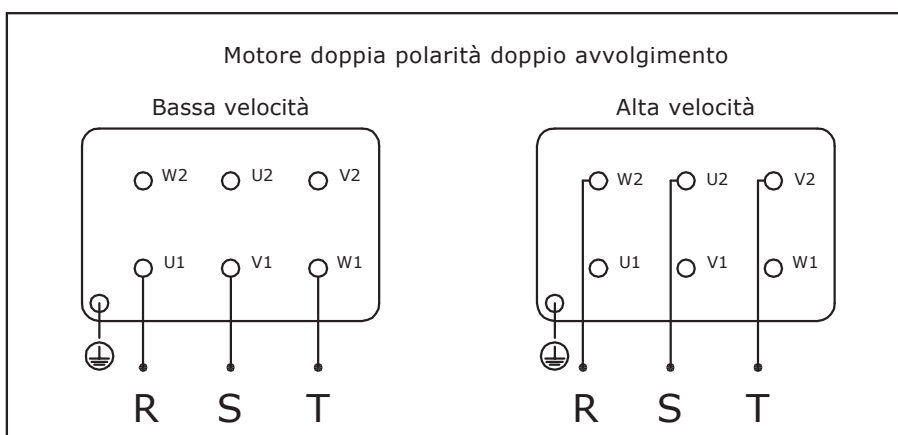

**SE05**

**SE05 M**

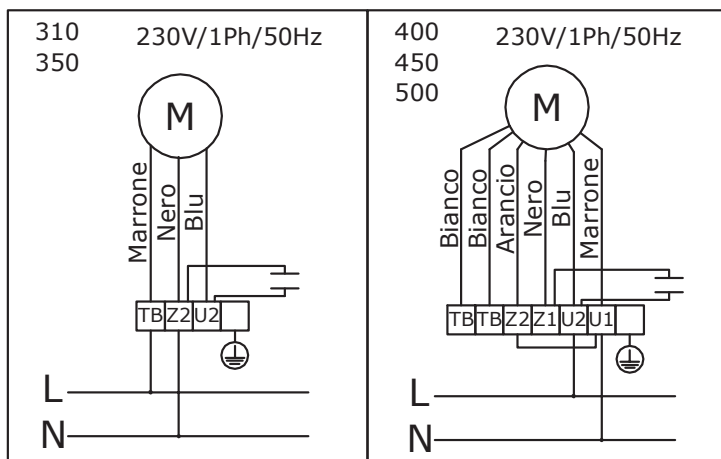

**SE05 T**

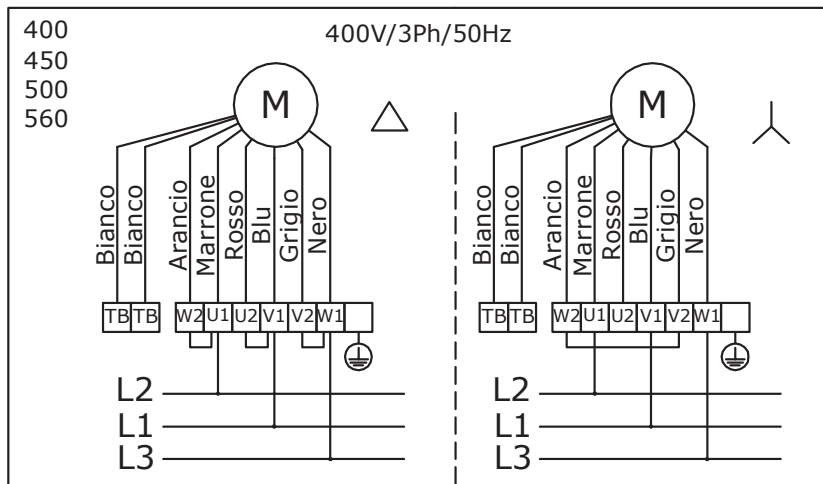

SE06

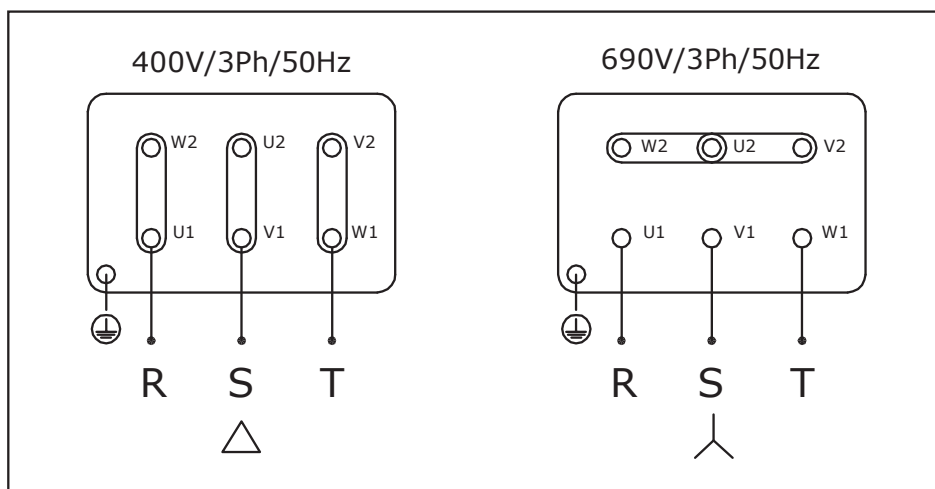
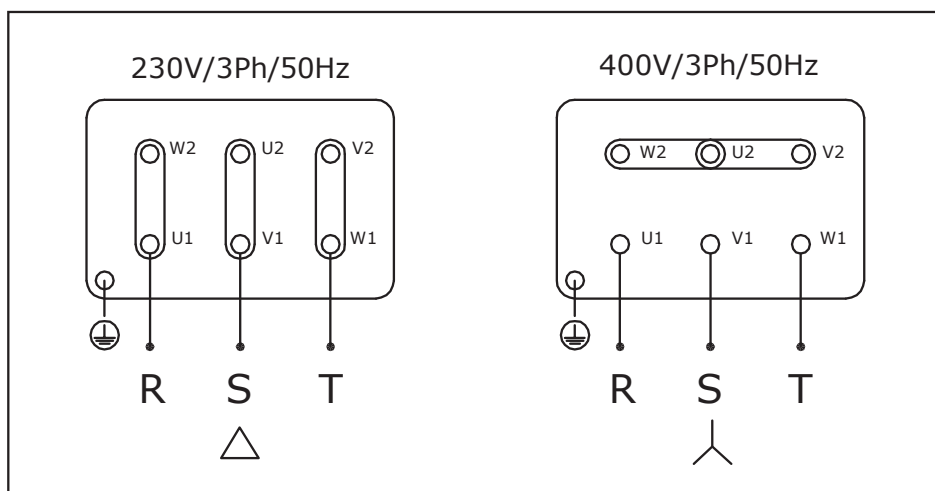

**SE08**

**SE08 M**

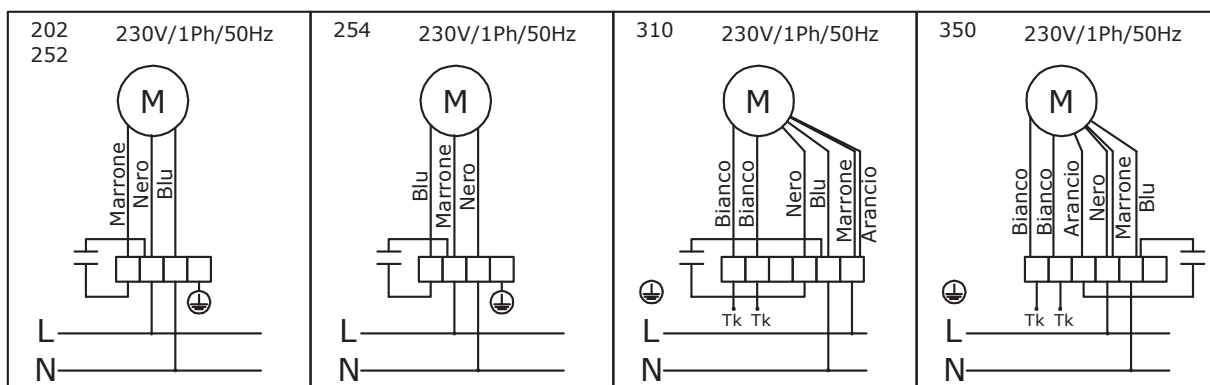

**SE08 T**

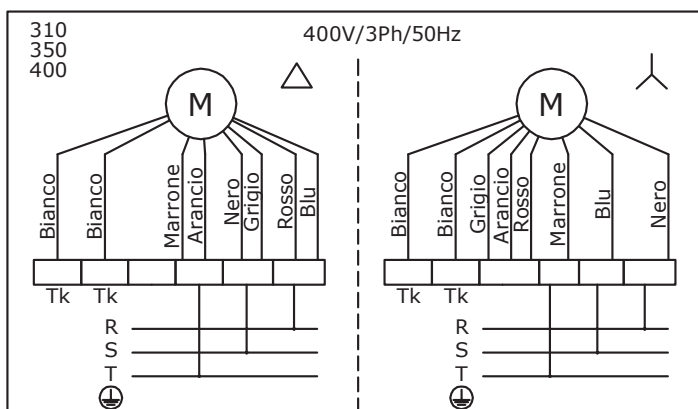

## SE09

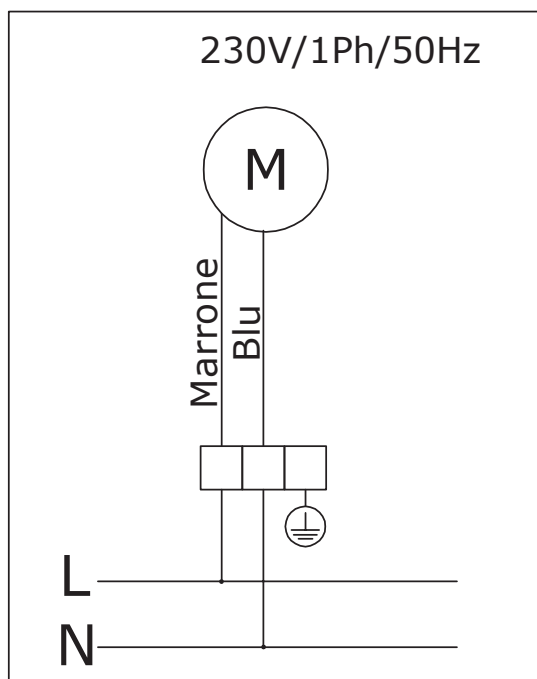



**SE10**

**SE10 M**

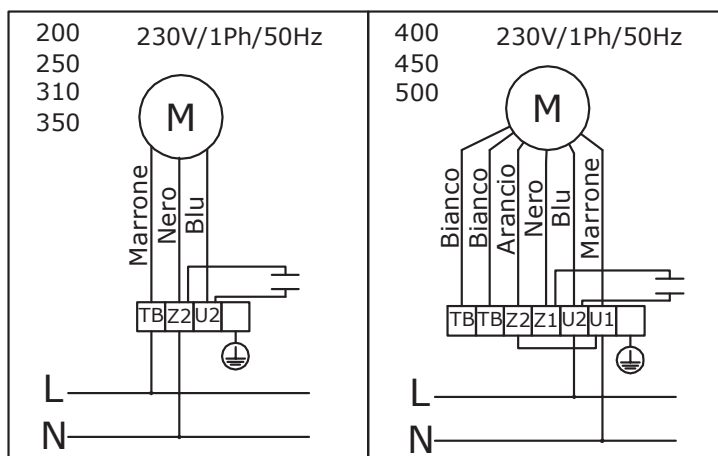

**SE10 T**

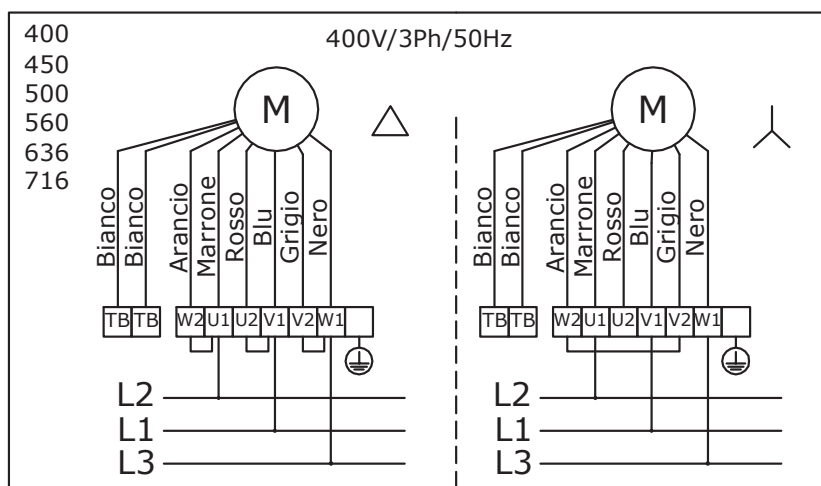

SE11

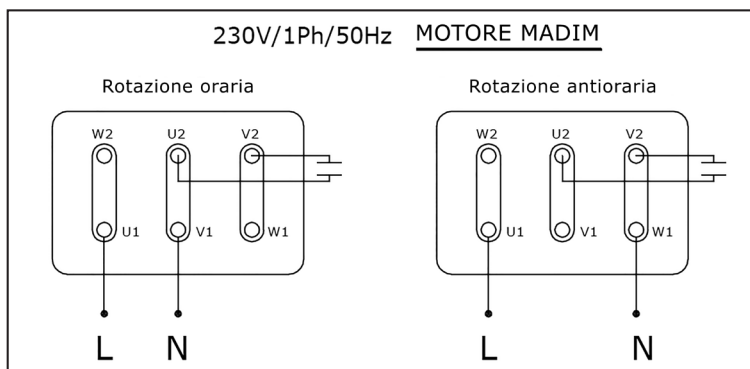
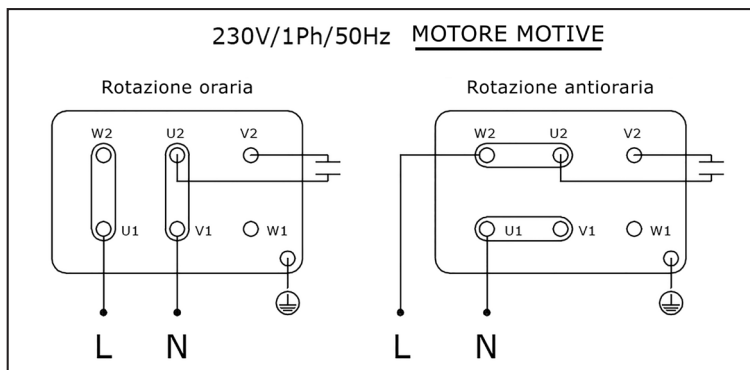
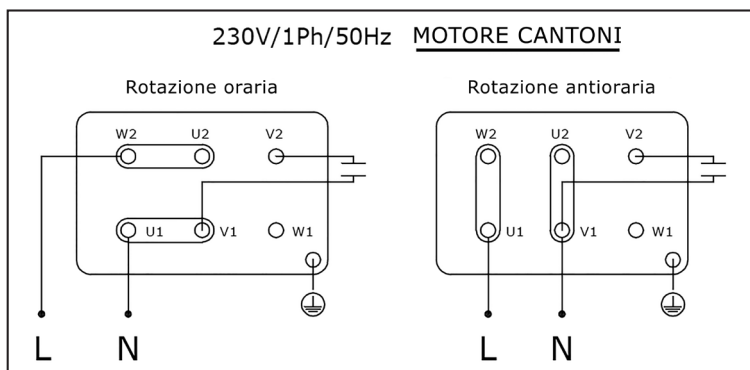
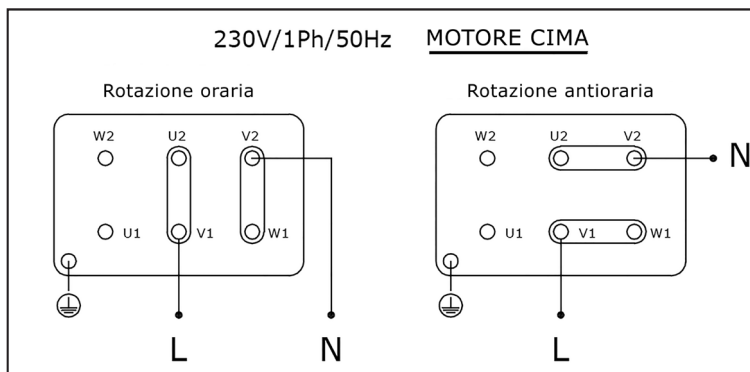

SE12

