



HD100



HYGIENE
Hand Dryer **CLASSIC**



HD100P
Manual

HD100A
Automatic



TECHNICAL SPECIFICATION

Airflow (m ³ /h)	240
RPM	2.800
Air velocity (Km/h)	65
Air temperature	52°C
Motor Power (W)	140
Heating element power (W)	1500
Consumption (A)	7
Noise level (dBA)	58
Voltage (V)	220-240
Frequency (Hz)	50/60
Electrical insulation	Class II -
Drying time	35 sec
Weight Kg	3 Kg
Protection	IP21

FEATURES

- Compact, one-piece cover made of UV resistant ABS white plastic, 3 mm thick.
- Cover fixed to the base by 4 screws.
- Air outlet grille in Zamak.
- Manual start-up through pushbutton which activates an electronic timer with a 40 seconds cycle.
- Warm airflow (52°C) at high velocity (65 Km/h) for a quick drying.
- Housing and impeller in fire-resistant ABS plastic UL 94-V0.
- Waved wired NiCr heating element with self-resetable thermal cut-off.
- Class F motor, incorporating a safety thermostat and a self-resetable thermal cut-off at 70°C.



- Classic design
- Compact
- Manual or Automatic versions
- Ideal for medium traffic facilities

DIMENSIONS (mm)

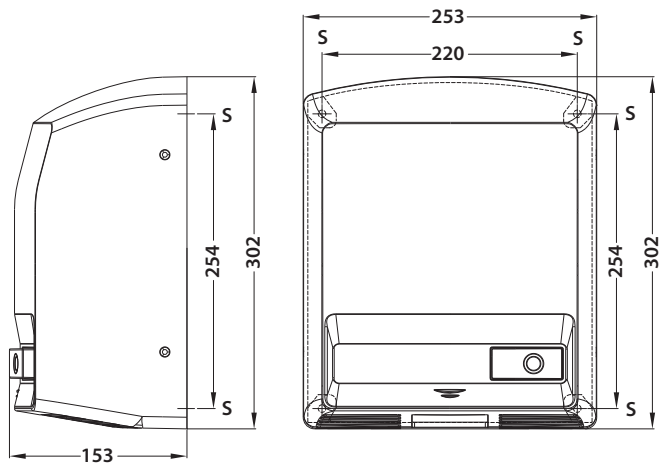

S = screw holes