



Serie **PF AT**



Aspiratori centrifughi pale rovesce
per aria pulita o molto polverosa



400 V

IP₅₅

min
-10°C

max
+300°C

CE

DESCRIZIONE

I ventilatori della serie **PF AT** trovano la loro principale applicazione negli impianti industriali per l'estrazione di segatura, trucioli vari, materiali granulari ad esclusione dei materiali filamentosi.

GAMMA

Diametri da 220 a 1.400 mm

Portate da 800 a 98.400 m³/h

La serie prevede esecuzioni direttamente accoppiate (esecuzione 4) e a trasmissione (esecuzione 1, 9 e 12).

TEMPERATURA DI ESERCIZIO

Temperature da -10°C fino a 150° (esecuzione 4) e 300°C (esecuzioni 1-12).

COSTRUZIONE

- Cassa a spirale realizzata in lamiera d'acciaio e protetta contro gli agenti atmosferici con vernici a polveri epossipoliestiriche.
- Boccaglio d'aspirazione con ampio raggio realizzato in lamiera d'acciaio e protetto contro gli agenti atmosferici con vernici a polveri epossipoliestiriche.
- Girante a semplice aspirazione con pale rovesce curve ad alto rendimento aeraulico, realizzata in lamiera e verniciata con vernici a polveri epossipoliestiriche. Sono previste versioni per alte velocità di rotazione in classe 3.
- Per esecuzione 1 – 9 – 12: supporto monoblocco realizzato in fusione di ghisa, con cuscinetti a sfera, progettati per agevolare le operazioni di lubrificazione. Cinghie di trasmissione, pulegge e supporto motore. Carter di protezione per le cinghie.

MOTORE

Motore asincrono trifase a norme internazionali IEC 60034, IEC 60072, EMC 2014/30/UE, LVD 2014/35/UE e marcato CE IP55, classe F, idonei ad un servizio S1 (funzionamento continuo a carico costante).

ACCESSORI

- Controflangia per bocca aspirante
- Controflangia per bocca premente
- Rete di protezione per bocca aspirante
- Rete di protezione per bocca premente
- Giunto antivibrante per bocca aspirante
- Giunto antivibrante per bocca premente

VERSIONI



PF

Versione per temperatura aria standard da -10 a +60°C



PF ATEX

Versione antideflagrante secondo la Direttiva 2014/34/UE



PF INOX

Versione resistente all'azione corrosiva, realizzata con cassa, boccaglio e girante in acciaio inossidabile AISI304/316 L

CAMPO D'IMPIEGO

Questo grafico ha il solo scopo di rappresentare le aree di funzionamento dei modelli disponibili. Per una selezione precisa utilizzare i grafici prestazionali presenti di seguito oppure contattate il nostro servizio tecnico commerciale.

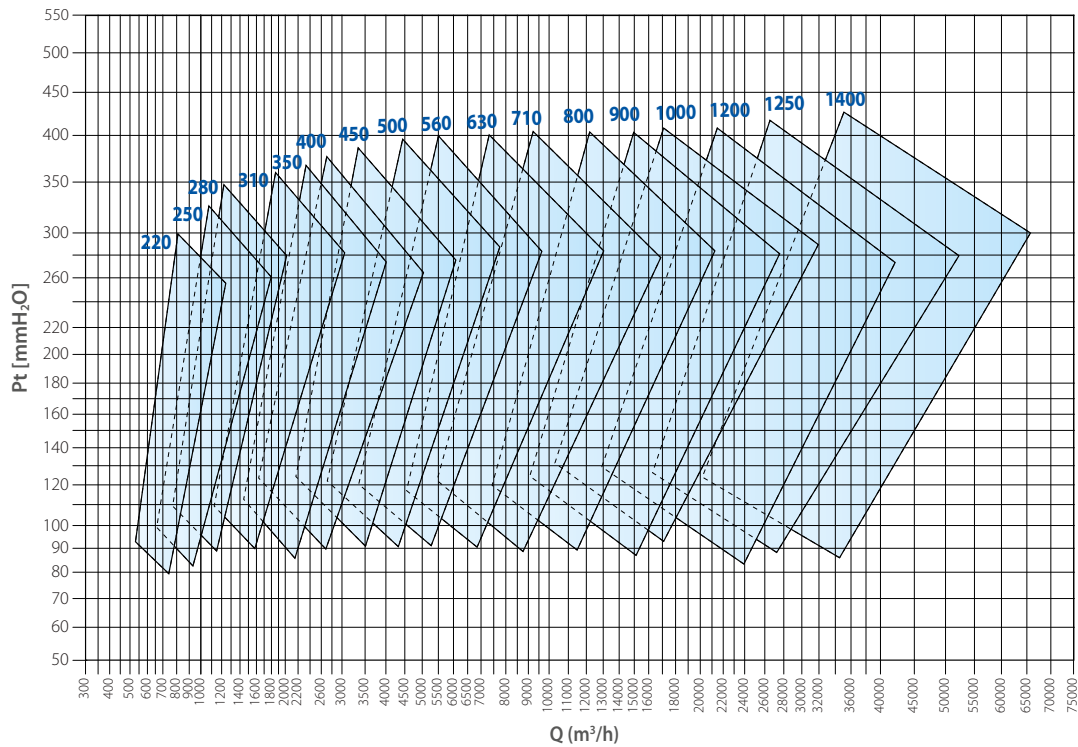

Grandezza ventilatore	RPM MAX		
	Classe I	Classe II	Classe III
PF AT 220	5200	6300	
PF AT 250 R	5200	6300	
PF AT 250	5200	6300	
PF AT 280 R	5000	5600	
PF AT 280	5000	5600	
PF AT 310 R	4800	5200	
PF AT 310	4550	5000	
PF AT 350 R	4350	4700	
PF AT 350	4150	4500	
PF AT 400 R	3950	4250	
PF AT 400	3750	4000	
PF AT 450 R	3550	3800	
PF AT 450	3350	3600	
PF AT 500 R	3250	3500	
PF AT 500	3150	3400	
PF AT 560 R	3050	3250	3550
PF AT 560	2960	3150	3300

Grandezza ventilatore	RPM MAX		
	Classe I	Classe II	Classe III
PF AT 630 R	2600	2960	3200
PF AT 630	2400	2800	3050
PF AT 710 R	2250	2700	2950
PF AT 710	2100	2500	2750
PF AT 800 R	2000	2400	2600
PF AT 800	1900	2200	2400
PF AT 900 R	1750	2100	2300
PF AT 900	1650	2000	2200
PF AT 1000 R	1550	1850	2050
PF AT 1000	1470	1700	1900
PF AT 1120 R	1350	1600	1750
PF AT 1120	1250	1485	1650
PF AT 1250 R	1150	1350	1550
PF AT 1250	1050	1250	1470
PF AT 1400 R	1000	1200	1350
PF AT 1400	950	1150	1300

VALORI RPM VALIDI FINO A 60°C

Fra	E	Declassare velocità
60°C	100°C	4%
100°C	150°C	10%
150°C	200°C	16%
200°C	250°C	23%
250°C	300°C	30%
300°C	350°C	37%
350°C	400°C	45%
400°C	450°C	54%
450°C	500°C	64%

PRESTAZIONI

CODICE	MODELLO	POLI	TENSIONE a 50Hz V	POTENZA kW	CORRENTE ASSORBITA A	MOTERE		PORTATA max (Q) m ³ /h	PRESSIONE MAX Pa Tot @Q max
						IP/CL	IE3		
A RICHIESTA	PF AT 222	2	400	0,18	0,60	55/F	-	790	441
A RICHIESTA	PF AT 252 R	2	400	0,25	0,90	55/F	-	1.080	471
A RICHIESTA	PF AT 252	2	400	0,37	1,10	55/F	-	1.370	431
A RICHIESTA	PF AT 282 R	2	400	0,55	1,27	55/F	-	1.620	520
A RICHIESTA	PF AT 282	2	400	0,75	1,90	55/F	✓	1.800	686
A RICHIESTA	PF AT 312 R	2	400	1,1	2,50	55/F	✓	2.520	726
A RICHIESTA	PF AT 312	2	400	1,5	3,40	55/F	✓	2.520	990
A RICHIESTA	PF AT 352 R	2	400	1,5	3,40	55/F	✓	2.160	1.765
A RICHIESTA	PF AT 352	2	400	2,2	4,90	55/F	✓	3.960	1.216
A RICHIESTA	PF AT 402 R	2	400	3	6,40	55/F	✓	5.400	1.098
A RICHIESTA	PF AT 402	2	400	4	8,00	55/F	✓	6.120	961
A RICHIESTA	PF AT 452 R	2	400	5,5	10,80	55/F	✓	7.920	1.265
A RICHIESTA	PF AT 452	2	400	7,5	14,10	55/F	✓	7.920	1.647
A RICHIESTA	PF AT 502 R	2	400	11	20,60	55/F	✓	1.800	1.442
A RICHIESTA	PF AT 502	2	400	15	27,50	55/F	✓	10.800	2.265
A RICHIESTA	PF AT 504 R	4	400	1,1	2,70	55/F	✓	4.680	461
A RICHIESTA	PF AT 504	4	400	1,5	3,60	55/F	✓	5.400	471
A RICHIESTA	PF AT 562 R	2	400	18,5	33,50	55/F	✓	16.200	1.540
A RICHIESTA	PF AT 562	2	400	22	39,50	55/F	✓	16.200	2.540
A RICHIESTA	PF AT 564 R	4	400	2,2	5,40	55/F	✓	7.200	510
A RICHIESTA	PF AT 564	4	400	3	6,80	55/F	✓	7.920	549
A RICHIESTA	PF AT 634 R	4	400	4	8,50	55/F	✓	10.000	588
A RICHIESTA	PF AT 634	4	400	5,5	11,30	55/F	✓	10.800	853
A RICHIESTA	PF AT 714 R	4	400	7,5	14,70	55/F	✓	14.400	765
A RICHIESTA	PF AT 714	4	400	11	22,00	55/F	✓	18.000	726
A RICHIESTA	PF AT 804 R	4	400	15	29,00	55/F	✓	21.600	1.079
A RICHIESTA	PF AT 804	4	400	18,5	35,00	55/F	✓	25.200	1.010
A RICHIESTA	PF AT 806 R	6	400	4	9,10	55/F	✓	14.400	422
A RICHIESTA	PF AT 806	6	400	5,5	12,30	55/F	✓	16.200	471
A RICHIESTA	PF AT 904 R	4	400	30	56,50	55/F	✓	32.400	1.314
A RICHIESTA	PF AT 904	4	400	37	68,00	55/F	✓	32.400	1.893
A RICHIESTA	PF AT 906 R	6	400	7,5	15,20	55/F	✓	21.600	598
A RICHIESTA	PF AT 906	6	400	11	22,00	55/F	✓	21.600	784
A RICHIESTA	PF AT 1004 R	4	400	45	80,50	55/F	✓	43.200	1.716
A RICHIESTA	PF AT 1004	4	400	55	97,61	55/F	✓	46.800	2.216
A RICHIESTA	PF AT 1006 R	6	400	15	29,00	55/F	✓	28.800	745
A RICHIESTA	PF AT 1006	6	400	18,5	35,20	55/F	✓	32.400	873
A RICHIESTA	PF AT 1124 R	4	400	75	134,00	55/F	✓	61.200	1.942
A RICHIESTA	PF AT 1124	4	400	90	152,96	55/F	✓	98.400	2.599
A RICHIESTA	PF AT 1126 R	6	400	22	42,50	55/F	✓	39.600	932
A RICHIESTA	PF AT 1126	6	400	30	55,62	55/F	✓	46.800	1.010
A RICHIESTA	PF AT 1256 R	6	400	37	68,00	55/F	✓	54.000	1.353
A RICHIESTA	PF AT 1256	6	400	45	78,93	55/F	✓	61.200	1.569
A RICHIESTA	PF AT 1406 R	6	400	55	96,24	55/F	✓	76.500	1.481
A RICHIESTA	PF AT 1406	6	400	75	132,96	55/F	✓	86.400	1.991

CURVE

Le curve prestazionali rappresentate nel presente catalogo sono state ricavate eseguendo prove sui ventilatori in accordo alla normativa ISO 5801 "Metodi di prova e condizioni di accettazione" (che sostituisce la ISO 1053:1995 ed è in accordo con la UNI EN ISO 5801:2009). Per eseguire le prove i ventilatori sono stati installati secondo quanto previsto per la categoria B: con bocca d'aspirazione libera e bocca premente collegata al banco prova. L'efficienza dei ventilatori è conforme all'obiettivo del regolamento (UE)N.327/2011, come richiesto dalla Direttiva 2009/125/CE.

Lw: La determinazione del livello di potenza sonora è stata condotta secondo la norma UNI EN ISO 3746: 1997 (Metodo di controllo con una superficie avvolgente su un piano riflettente). Alle misure sono state applicate correzioni in funzione del rumore di fondo e del riverbero ambientale.

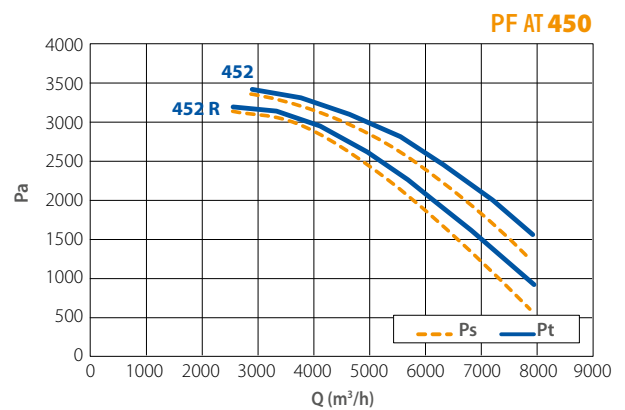
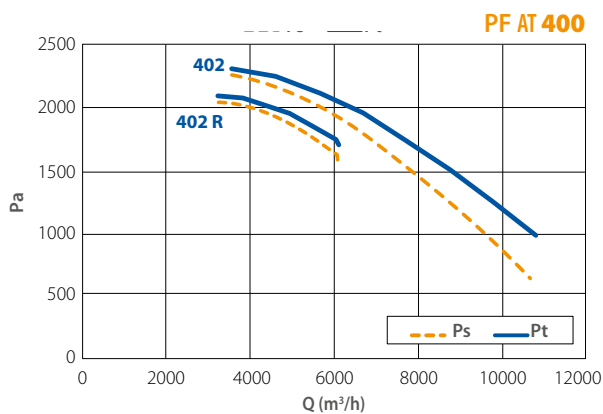
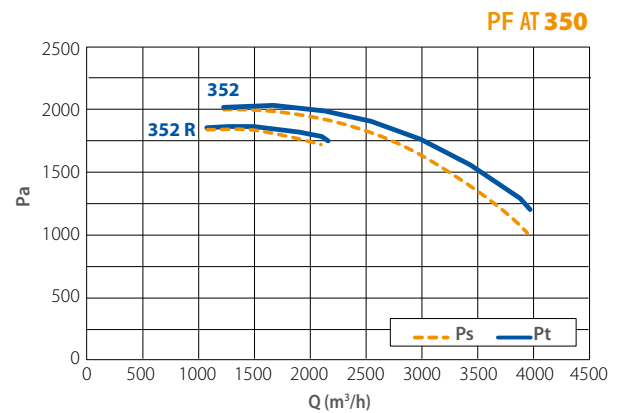
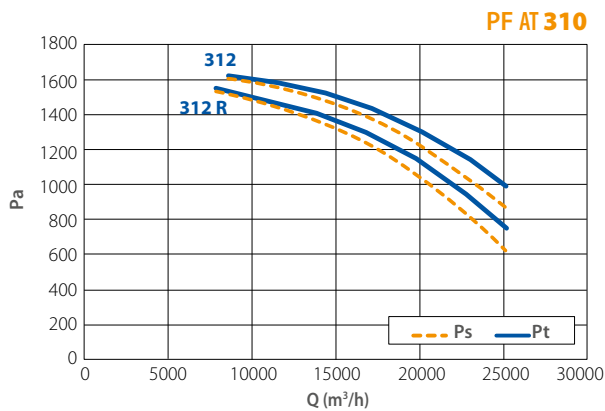
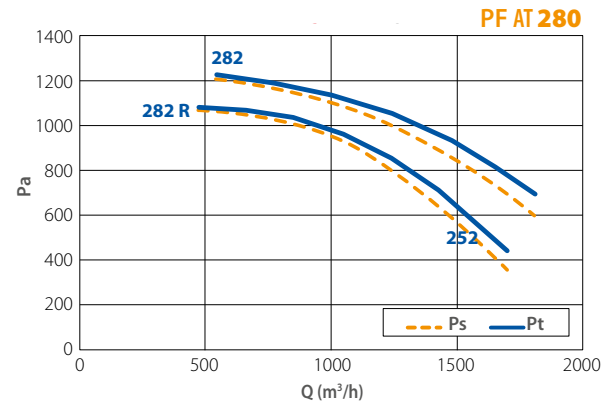
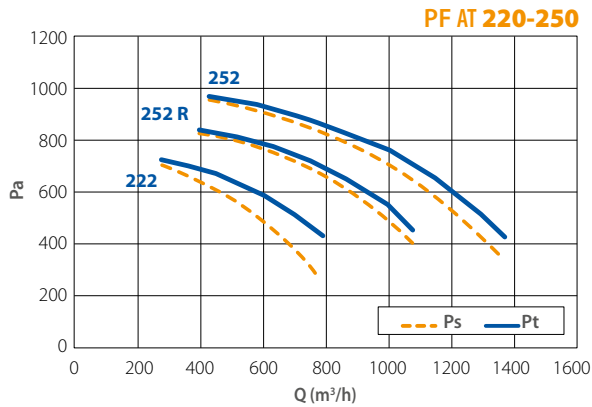

CURVE

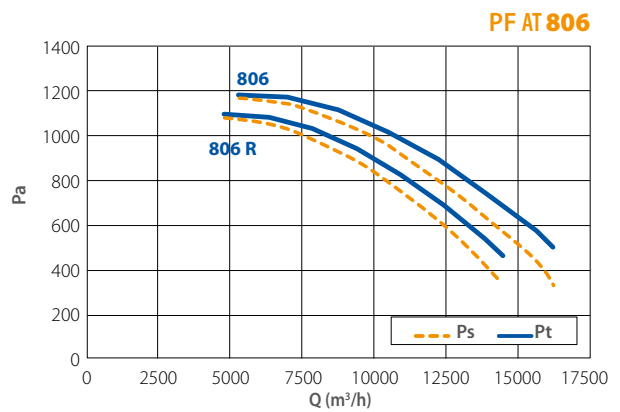
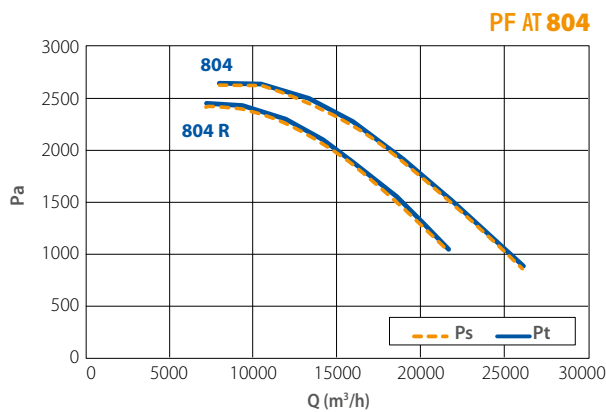
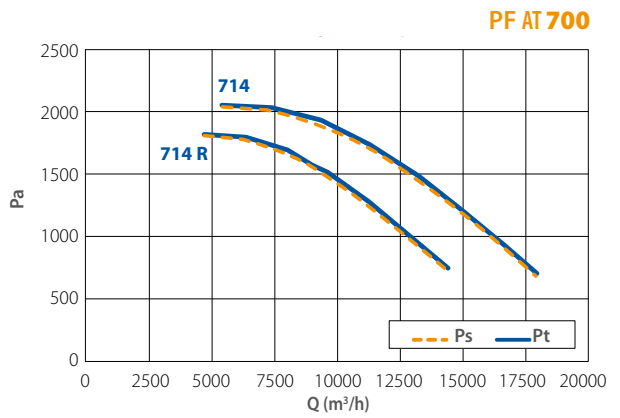
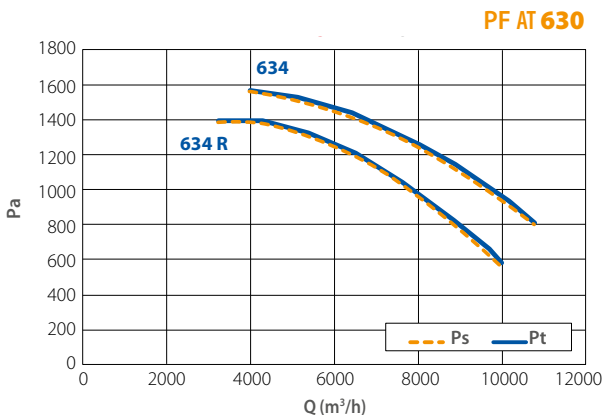
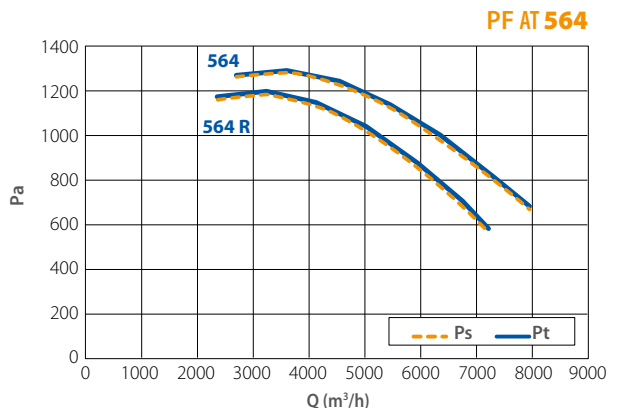
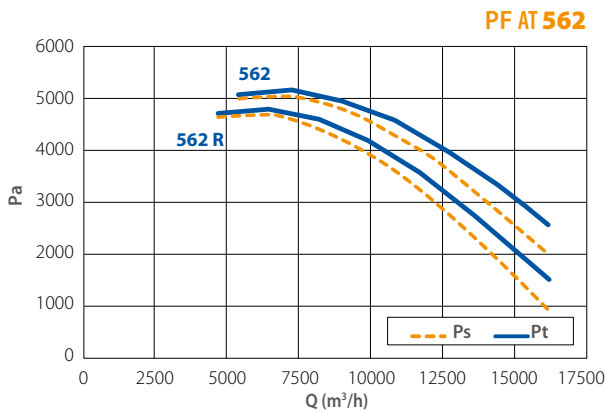
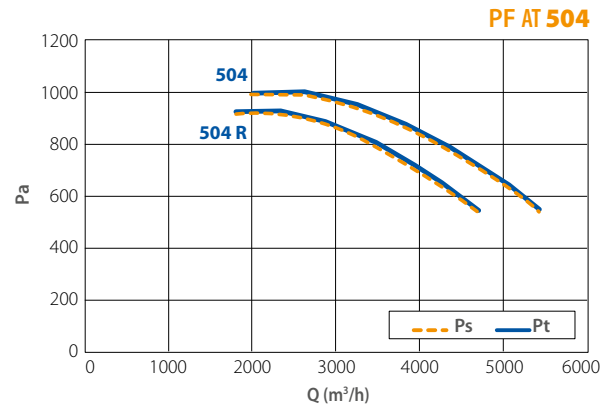
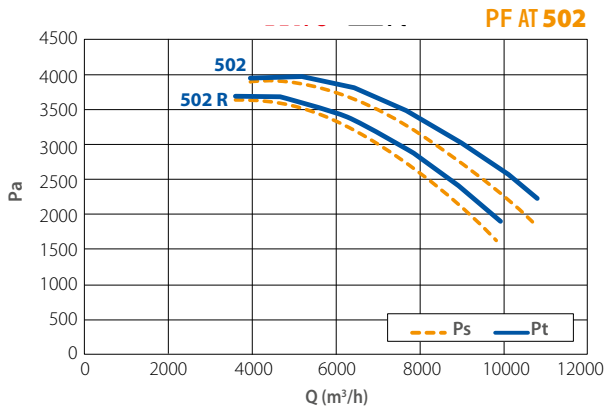

CURVE

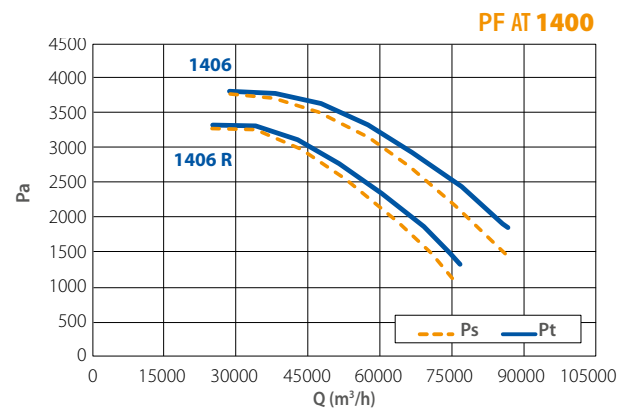
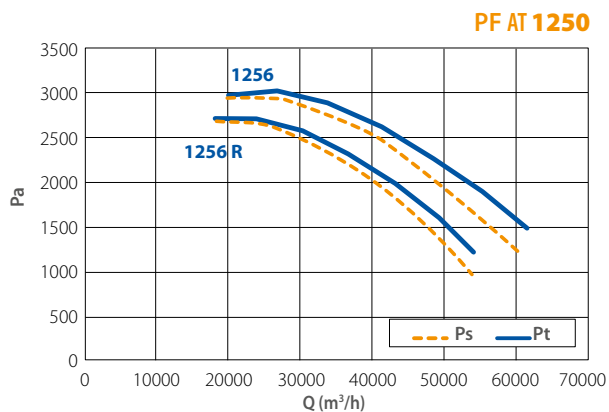
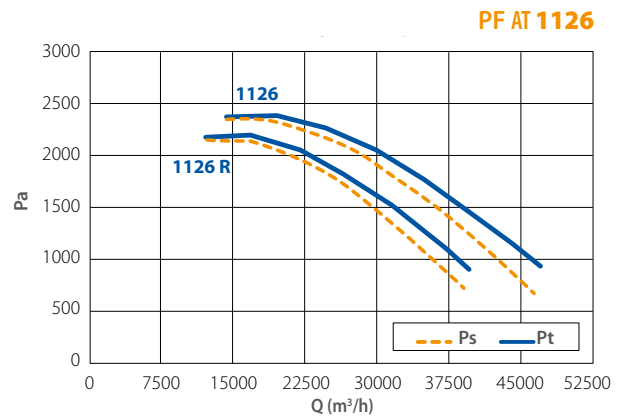
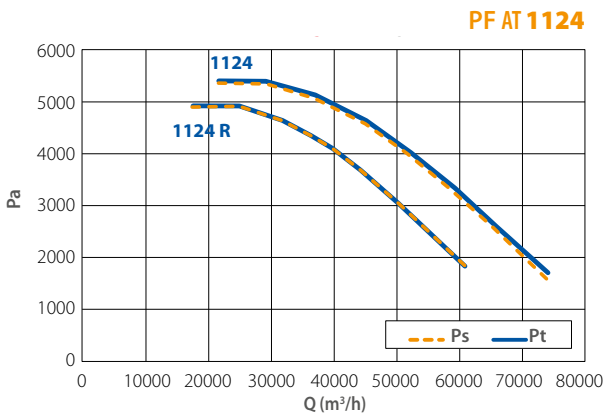
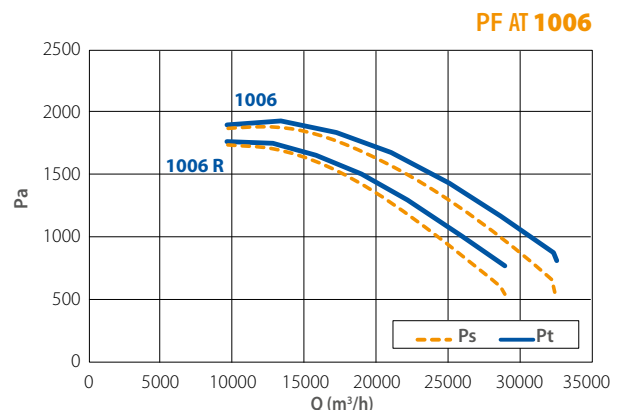
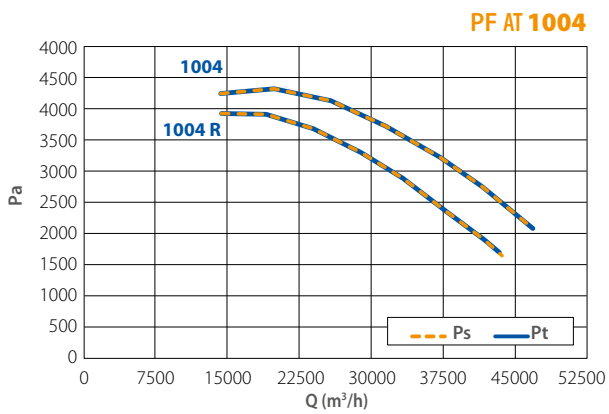
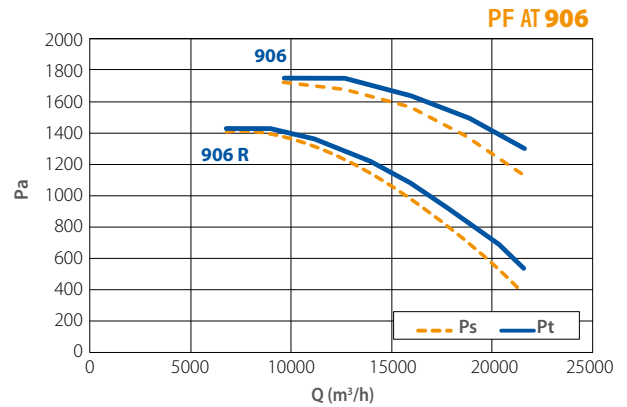
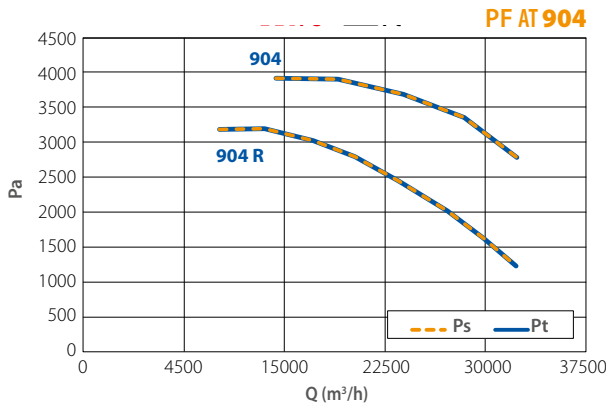

DIMENSIONI (mm)

ESECUZIONE 4

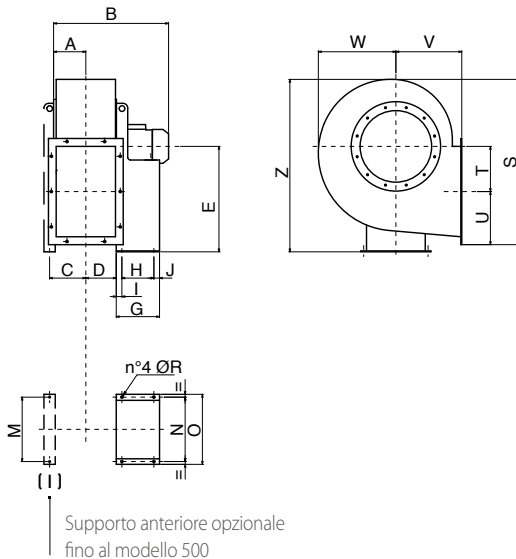

TIPO	A	B	C	D	E	G	H	I	J	M	N	O	ØR	Z	S	T	U	V	W
PF AT 222	59	307	69	55	255	150	86	48	16	250	184	206	10	430	407	150	82	165	226
PF AT 252 R	86	366	92	77	315	150	86	48	16	280	184	206	10	527	525	175	139	195	276
PF AT 252	86	396	92	77	315	195	121	48	26	280	203	206	10	527	525	175	139	195	276
PF AT 282 R	95	414	103	86	375	196	121	49	26	315	203	225	10	606	583	202	151	200	305
PF AT 282	95	438	103	86	375	217	121	48	48	315	203	225	10	606	583	202	151	200	305
PF AT 312 R	105	458	103	96	400	217	121	48	48	350	203	225	10	656	649	229	164	225	332
PF AT 312	105	505	103	96	400	251	133	60	58	350	234	225	10	656	649	229	164	225	332
PF AT 352 R	115	530	128	106	450	251	133	58	60	395	234	260	10	738	725	253	184	255	375
PF AT 352	115	530	128	106	450	251	133	58	60	395	234	260	10	738	725	253	184	255	375
PF AT 402 R	127	585	145	118	500	283	197	34	52	445	289	324	12	811	798	286	201	285	400
PF AT 402	127	606	145	118	500	285	197	34	54	445	289	324	12	811	798	286	201	285	400
PF AT 452 R	141	673	158	132	560	345	237	44	64	495	337	372	12	914	895	321	221	320	445
PF AT 452	141	673	158	132	560	345	237	44	64	495	337	372	12	914	895	321	221	320	445
PF AT 502 R	157	810	174	148	600	446	337	55	54	545	395	440	14	1000	997	355	242	360	502
PF AT 502	157	810	174	148	600	446	337	55	54	545	395	440	14	1000	997	355	242	360	502
PF AT 504 R	157	613	174	148	600	251	133	58	60	545	234	440	14	1000	997	355	242	360	502
PF AT 504	157	613	174	148	600	251	133	58	60	545	234	440	14	1000	997	355	242	360	502

ESECUZIONE 4

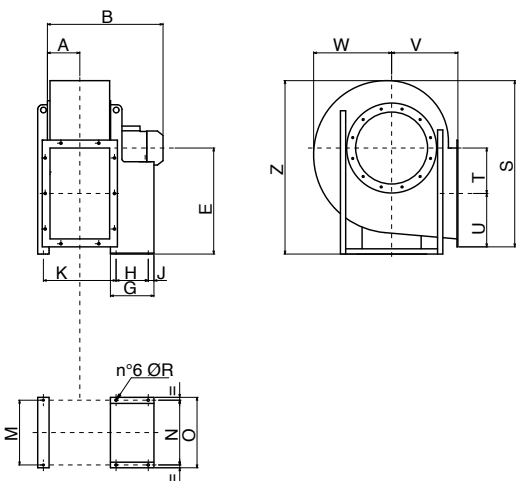

TIPO	A	B	E	G	H	J	K	N	O	ØR	M	Z	S	T	U	V	W
PF AT 562 R	177	857	670	441	337	54	406	395	440	14	632	1154	1141	390	267	400	570
PF AT 562	177	938	670	465	357	38	426	434	440	17	632	1154	1141	390	267	400	570
PF AT 564 R	177	691	670	281	197	54	386	289	488	12	632	1154	1141	390	267	400	570
PF AT 564	177	691	670	281	197	54	386	289	324	12	632	1154	1141	390	267	400	570
PF AT 634 R	195	752	750	281	197	54	425	289	324	12	702	1299	1282	439	294	450	630
PF AT 634	195	792	750	341	237	64	435	337	372	12	702	1299	1282	439	294	450	630
PF AT 714 R	216	837	850	336	201	75	497	772	826	20	772	1414	1399	500	335	500	690
PF AT 714	216	942	850	436	316	60	497	772	826	20	772	1414	1399	500	335	500	690
PF AT 804 R	241	1011	950	436	315	60	546	862	926	20	862	1591	1570	560	369	560	782
PF AT 804	241	1092	950	460	361	39	546	862	926	20	862	1591	1570	560	369	560	782
PF AT 806 R	241	906	950	336	201	75	546	862	926	20	862	1591	1570	560	369	560	782
PF AT 806	241	906	950	336	201	75	546	862	926	20	862	1591	1570	560	369	560	782
PF AT 904 R	275	1254	1060	500	401	39	600	962	1026	20	962	1780	1758	630	408	630	870
PF AT 904	275	1236	1060	540	441	39	600	962	1026	20	962	1780	1758	630	408	630	870
PF AT 906 R	275	1065	1060	436	316	60	600	962	1026	20	962	1780	1758	630	408	630	870
PF AT 906	275	1065	1060	436	316	60	600	962	1026	20	962	1780	1758	630	408	630	870
PF AT 1004 R	308	1378	1180	540	440	45	657	1056	1128	20	1056	1993	1984	710	461	710	976
PF AT 1004	308	1486	1180	600	500	45	657	1056	1128	20	1056	1993	1984	710	461	710	976
PF AT 1006 R	308	1279	1180	460	360	45	657	1056	1128	20	1056	1993	1984	710	461	710	976
PF AT 1006	308	1336	1180	500	400	45	657	1056	1128	20	1056	1993	1984	710	461	710	976
PF AT 1124 R	350	1558	1320	690	565	45	763	1178	1268	24	1178	2252	2241	800	509	800	1084
PF AT 1124	350	1558	1320	690	565	45	763	1178	1268	24	1178	2252	2241	800	509	800	1084
PF AT 1126 R	350	1405	1320	500	375	45	763	1178	1268	24	1178	2252	2241	800	509	800	1084
PF AT 1126	350	1447	1320	540	415	45	763	1178	1268	24	1178	2252	2241	800	509	800	1084
PF AT 1256 R	388	1632	1500	600	475	45	840	1310	1400	24	1310	2547	2511	900	564	900	1214
PF AT 1256	388	1635	1500	690	565	45	840	1310	1400	24	1310	2547	2511	900	564	900	1214
PF AT 1406 R	442	1751	1700	690	535	55	690	1450	1560	24	1450	2845	2780	1000	635	1000	1325
PF AT 1406	442	1963	1700	800	645	55	800	1450	1560	24	1450	2845	2780	1000	635	1000	1325

DIMENSIONI (mm)

ESECUZIONE 1

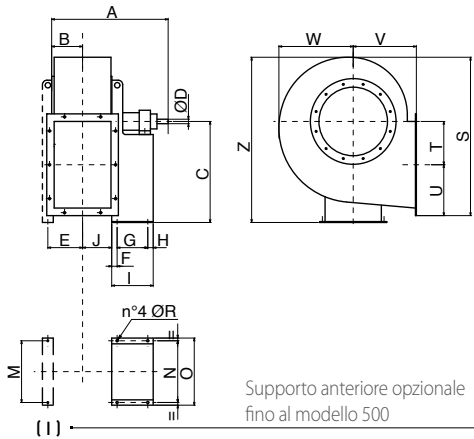

TIPO	A	B	C	ØD	E	F	G	H	I	J	M	N	O	ØR	S	T	U	V	W	Z
PF AT 220	455	59	300	19	69	61	210	17	288	55	250	228	255	10	407	150	82	165	226	475
PF AT 250	513	86	315	19	92	55	210	17	282	77	280	228	255	10	525	175	139	195	276	527
PF AT 280	616	95	375	24	103	40	284	23	347	86	315	228	264	12	583	202	151	200	305	606
PF AT 310	635	105	400	24	103	40	284	23	347	96	350	228	264	12	649	229	164	225	332	656
PF AT 350	806	115	450	28	128	50	407	28	485	106	395	355	400	14	725	253	184	255	375	738
PF AT 400	851	127	500	38	145	50	407	28	485	118	445	355	400	14	798	286	201	285	400	811
PF AT 450	870	141	560	38	158	50	407	28	485	132	495	355	400	14	895	321	220,5	320	445	913,5
PF AT 500	1011	157	600	42	174	50	477	33	560	148	545	364	418	17	997	355	242	360	502	1000

ESECUZIONE 1

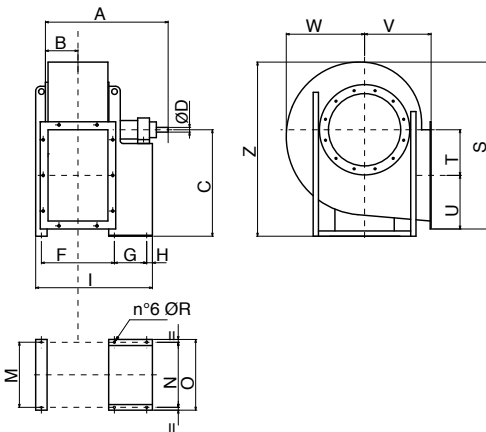

TIPO	A	B	C	ØD	F	G	H	I	M	N	O	ØR	S	T	U	V	W	Z
PF AT 560	1058	177	670	48	410	477	33	943	632	632	692	17	1141	390	267	400	570	1155
PF AT 630	1102	195	750	48	450	477	33	983	702	702	762	17	1282	439	294	450	630	1300
PF AT 710	1241	216	670	48	497	551	39	1114	772	772	826	19	1399	500	335	500	690	1415
PF AT 800	1306	241	755	55	546	551	39	1183	862	862	926	19	1570	560	369	560	782	1591
PF AT 900	1360	275	850	55	600	551	39	1237	962	962	1026	19	1758	630	408	630	870	1781
PF AT 1000	1565	308	950	65	657	607	45	1376	1056	1056	1128	19	1984	710	461	710	976	1994
PF AT 1120	1780	350	1060	75	763	760	45	1623	1178	1178	1268	24	2241	800	509	800	1084	2252
PF AT 1250	1855	388	1190	75	840	760	45	1700	1310	1310	1400	24	2511	900	564	900	1214	2548
PF AT 1400	2050	442	1320	80	946	780	55	1866	1450	1450	1560	24	2780	1000	635	1000	1325	2845

BOCCA ASPIRANTE

TIPO	ØR	ØS	ØT	n°F	ØG
PF AT 220	130	150	170	4	4
PF AT 250	185	219	250	8	8
PF AT 280	205	241	275	8	8
PF AT 310	228	265	298	8	8
PF AT 350	255	292	325	8	10
PF AT 400	285	332	365	8	12
PF AT 450	320	366	400	8	12
PF AT 500	360	405	440	8	12
PF AT 560	405	448	485	12	12
PF AT 630	455	497	535	12	12
PF AT 710	505	551	585	12	14
PF AT 800	565	629	665	12	14
PF AT 900	635	698	735	12	14
PF AT 1000	715	775	815	16	14
PF AT 1120	805	861	905	16	14
PF AT 1250	905	958	1005	16	14
PF AT 1400	1007	1067	1107	24	14

BOCCA PREMENTE

TIPO	A	B	a1	b1	a2	b2	N1 x p	N2 x p	n°D	ØE
PF AT 220	124	103	145	125	164	143	-	-	4	8
PF AT 250	207	148	241	182	277	218	1 x 112	1 x 112	8	12
PF AT 280	231	166	265	200	301	236	1 x 112	1 x 112	8	12
PF AT 310	258	185	292	219	328	255	1 x 112	2 x 112	10	12
PF AT 350	288	205	332	249	368	285	1 x 125	2 x 125	10	12
PF AT 400	322	229	366	273	402	309	1 x 125	2 x 125	10	12
PF AT 450	361	256	405	300	441	336	1 x 125	2 x 125	10	12
PF AT 500	404	288	448	332	484	368	2 x 125	3 x 125	14	12
PF AT 560	453	322	497	366	533	402	2 x 125	3 x 125	14	12
PF AT 630	507	361	551	405	587	441	2 x 125	3 x 125	14	12
PF AT 710	569	404	629	464	669	504	2 x 160	3 x 160	14	14
PF AT 800	638	453	698	513	738	553	2 x 160	3 x 160	14	14
PF AT 900	715	507	775	567	815	607	2 x 160	4 x 160	16	14
PF AT 1000	801	569	871	639	921	689	2 x 200	3 x 200	14	14
PF AT 1120	898	638	968	708	1018	758	3 x 200	4 x 200	18	14
PF AT 1250	1007	715	1077	785	1127	835	3 x 200	4 x 200	18	14
PF AT 1400	1130	801	1210	881	1270	941	3 x 200	5 x 200	20	18

DIMENSIONI (mm) E ORIENTAMENTI

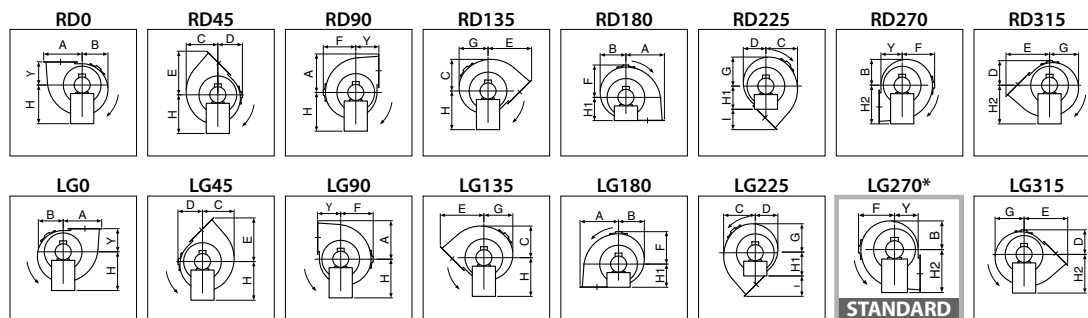

* Versione standard

Dimensioni dei modelli secondo l'orientamento.

TIPO	A	B	C	D	E	F	G	I	Y	H	H1	H2
PF AT 220	232	175	200	190	280	226	190	115	165	255	165	255
PF AT 250	314	212	255	215	360	276	235	165	195	315	195	315
PF AT 280	353	231	287	226	391	305	262	191	200	375	200	375
PF AT 310	393	256	316	253	437	332	288	212	225	400	225	400
PF AT 350	437	288	359	278	489	375	325	234	255	450	255	450
PF AT 400	487	311	387	306	546	400	353	261	285	500	285	500
PF AT 450	542	354	435	342	609	445	398	289	320	560	320	560
PF AT 500	597	400	490	380	677	502	450	317	360	600	360	600
PF AT 560	657	485	555	425	747	570	542	347	400	670	400	670
PF AT 630	733	550	619	476	836	630	603	386	450	750	450	750
PF AT 710	835	565	719	497	944	690	662	444	500	670	500	850
PF AT 800	929	641	811	562	1053	782	749	493	560	755	560	950
PF AT 900	1038	721	905	633	1180	870	835	550	630	850	630	1060
PF AT 1000	1171	814	1015	718	1330	976	936	620	710	950	710	1180
PF AT 1120	1309	932	1133	793	1491	1084	1037	691	800	1060	800	1320
PF AT 1250	1464	1048	1270	898	1671	1214	1163	771	900	1190	900	1500
PF AT 1400	1635	1145	1395	990	1863	1325	1272	863	1000	1320	1000	1700

PESI

MODELLO	Kg*	MODELLO	Kg*	MODELLO	Kg*	MODELLO	Kg*	MODELLO	Kg*
PF AT 222	18	PF AT 402 R	85	PF AT 562	276	PF AT 806 R	391	PF AT 1006	850
PF AT 252 R	24	PF AT 402	93	PF AT 564 R	128	PF AT 806	395	PF AT 1124 R	1445
PF AT 252	26	PF AT 452 R	115	PF AT 564	136	PF AT 904 R	684	PF AT 1124	1486
PF AT 282 R	30	PF AT 452	118	PF AT 634 R	190	PF AT 904	767	PF AT 1126 R	955
PF AT 282	35	PF AT 502 R	175	PF AT 634	205	PF AT 906 R	511	PF AT 1126	1156
PF AT 312 R	42	PF AT 502	180	PF AT 714 R	287	PF AT 906	531	PF AT 1256 R	1430
PF AT 312	45	PF AT 504 R	100	PF AT 714	338	PF AT 1004 R	963	PF AT 1256	1915
PF AT 352 R	66	PF AT 504	106	PF AT 804 R	504	PF AT 1004	1081	PF AT 1406 R	1850
PF AT 352	70	PF AT 562 R	220	PF AT 804	512	PF AT 1006 R	743	PF AT 1406	2366

* Pesi indicativi

LATO ASPIRANTE Flangia - Rete - Giunto

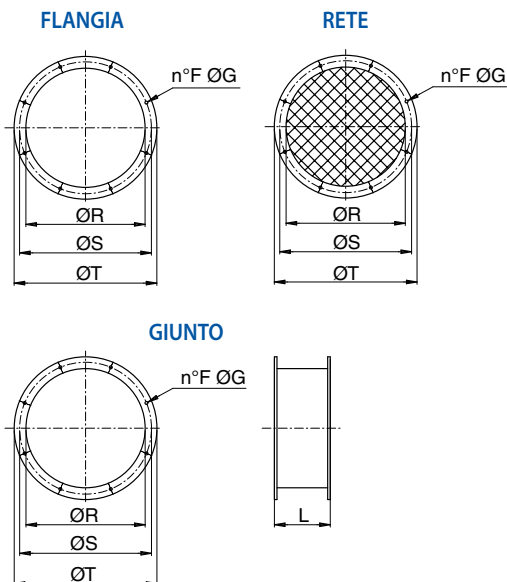

Flangia		Rete		Giunto						
CODICE	CODICE	CODICE	Tipo	ØR	ØS	ØT	F	ØG	L	
5B01321	5RE1025	5SU1404	220	130	150	170	4	4	145	
5B01325	5RE1021	5SU3142	250	185	219	250	8	8	145	
5B01328	5RE1017	5SU1405	280	205	241	275	8	8	145	
5B01327	5RE1018	5SU3137	310	228	265	298	8	8	145	
5B01323	5RE4050	5SU1096	350	255	292	325	8	10	145	
5B01364	5RE1027	5SU3147	400	285	332	365	8	12	145	
5B01334	5RE1002	5SU3101	450	320	366	400	8	12	145	
5B01330	5RE1022	5SU3500	500	360	405	440	8	12	145	
5B01347	5RE5606	5SU1102	560	405	448	485	12	12	145	
5B08105	5RE1046	5SU1406	630	455	497	535	12	12	145	
5B01380	5RE1180	5SU1180	710	505	551	585	12	14	180	
5B08087	5RE1016	5SU8004	800	565	629	665	12	14	180	
5B01391	5RE1013	5SU9000	900	635	698	735	12	14	180	
5B08101	5RE1015	5SU1100	1000	715	775	815	16	14	180	
5B01357	5RE0815	5SU8000	1120	805	861	905	16	14	180	
5B01359	5RE0090	5SU9002	1250	905	958	1005	16	14	230	
5B01408	5RE1010	5SU1144	1400	1007	1067	1107	24	14	230	

Dimensioni in mm

LATO PREMENTE Flangia - Rete - Giunto

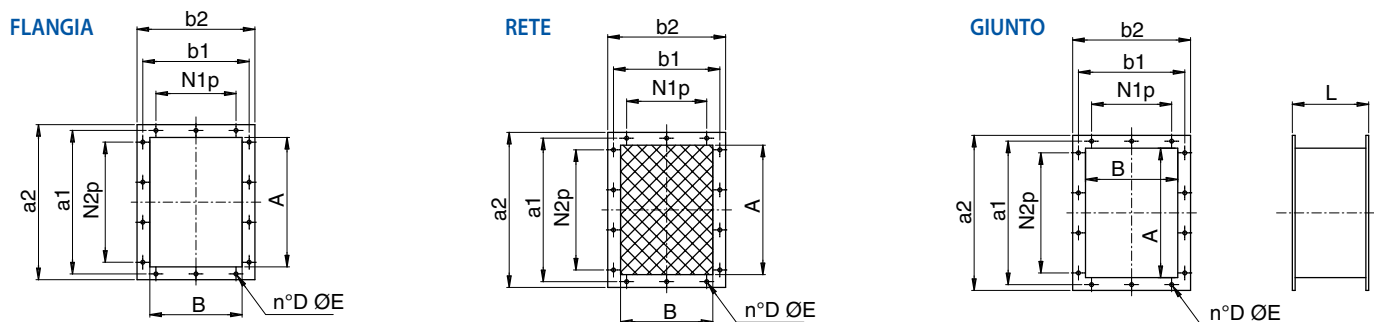

Flangia		Rete		Giunto										
CODICE	CODICE	CODICE	Tipo	A	B	a1	b1	a2	b2	N1 xp	N2 xp	n°D	øE	L
5B01358	5RE1026	5SU1407	220	124	103	145	125	164	143	-	-	4	8	145
5B05019	5RE4051	5SU3143	250	207	148	241	182	277	218	1 x 112	1 x 112	8	12	145
5B01329	5RE1019	5SU1131	280	231	166	265	200	301	236	1 x 112	1 x 112	8	12	145
5B01324	5RE3138	5SU3138	310	258	185	292	219	328	255	1 x 112	2 x 112	10	12	145
5B01365	5RE1130	5SU1130	350	288	205	332	249	368	285	1 x 125	2 x 125	10	12	145
5B01362	5RE1348	5SU3148	400	322	229	366	273	402	309	1 x 125	2 x 125	10	12	145
5B01340	5RE1023	5SU3501	450	361	256	405	300	441	336	1 x 125	2 x 125	10	12	145
5B01344	5RE1020	5SU4023	500	404	288	448	332	484	368	2 x 125	3 x 125	14	12	145
5B01348	5RE1006	5SU5601	560	453	322	497	366	533	402	2 x 125	3 x 125	14	12	145
5B01381	5RE1024	5SU1181	630	507	361	551	405	587	441	2 x 125	3 x 125	14	12	145
5B08104	5RE1004	5SU4021	710	569	404	629	464	669	504	2 x 160	3 x 160	14	14	180
5B01310	5RE1035	5SU1402	800	638	453	698	513	738	553	2 x 160	3 x 160	14	14	180
5B01390	5RE1009	5SU1101	900	715	507	775	567	815	607	2 x 160	4 x 160	16	14	180
5B01392	5RE3079	5SU3079	1000	801	569	871	639	921	689	2 x 200	3 x 200	14	14	180
5B01360	5RE9003	5SU9003	1120	898	638	968	708	1018	758	3 x 200	4 x 200	18	14	180
5B08100	5RE1128	5SU1128	1250	1007	715	1077	785	1127	835	3 x 200	4 x 200	18	14	180
5B01399	5RE1399	5SU1399	1400	1130	801	1210	881	1270	941	3 x 200	5 x 200	20	18	180

Dimensioni in mm